



North Carolina
humanities

Crossroads: Change in Rural America Exhibition Summary

Contents

Exhibition Overview.....	2
Exhibition Specifications.....	10
Exhibition Content Summary.....	13

Exhibition Overview

Crossroads' Guiding Questions

What does “rural America” mean?

How has our attraction to and interaction with the land formed the basis of rural America?

How have rural communities and small towns evolved and changed?

What makes these places unique?

How do we identify with them?



Major Themes



Changes transformed rural America (including global influences), especially during the 1900s.

What are some of these changes, and what have they meant for rural life?



People are holding on in their rural communities. Why and how?

What is rural life like today? How are rural Americans shaping their future?

Introduction

Americans come together at crossroads. Small towns are centers for:

- Commerce and trade
- Local politics
- Culture and ideas

Rural America changed significantly in the 1900s:

- Demographics
- Education
- Access to services
- Economic viability

Rural communities may face challenges as well as opportunities





Identity

American culture is filled with romantic views of rural life and culture.

Living and working in a rural place can also be difficult.

How is rural America represented in books, songs, poetry, and art?

How do rural ideals square with American ideals?

- Economic opportunity
- Personal liberty
- Equality

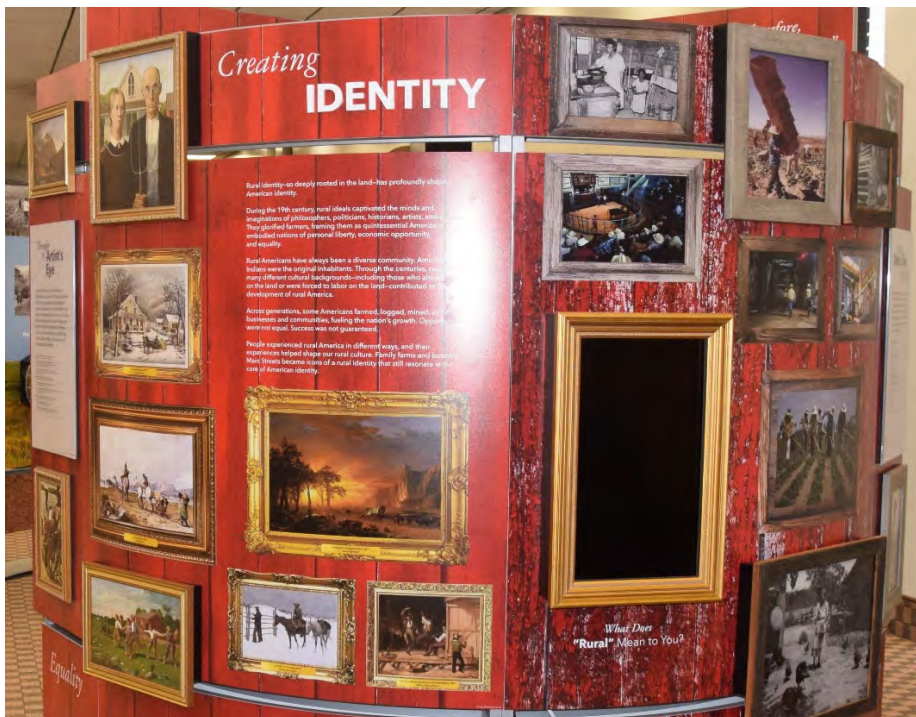

Land



Land is core to our concept of rural life.

Our sense of place is powerful.
Many Americans express strong connections to the rural landscape.
Memories of recreation in rural places.
Natural beauty draws people to rural areas.
For some, rural landscapes represent hard work and isolation.



Not everyone is a landowner. Most Americans connect with rural places through public lands.

How do attitudes towards land ownership and access differ among Americans?

Are there stories of conflict over land in your state?

Community

Communities grew at rural crossroads

- People connect, exchange ideas, work towards common goals, rely on neighbors, and build the future of their community.

Sustaining communities

- Country Life Movement
- New Deal and rural electrification programs

Accelerated change

- Change in the second half of the 20th century
- Erosion of political power in some states
- Demographic changes
- Civil rights struggles
- Aging populations
- Challenges of inequality and poverty





Persistence

Rural Americans believe in their communities and many choose to work to resolve issues rather than leaving.

Economic survival requires revitalization of small towns, and inspires new ways of thinking about farming and extractive industries.

Many Americans are discovering the benefits of rural life. The slower pace and quiet surroundings, proximity to natural resources etc.

Popular culture connects urban and suburban Americans to rural life. Rural life and people are often romanticized or satirized.



Managing Change

Some rural communities face significant challenges.

Americans are confronting these issues and finding new and unique solutions.

There are many different voices to welcome into these conversations.

What will your town look like in ten years?

What has your community lost that matters most?

What change for good would you make in your town?

As a Major, what would you do?

Name three things you would miss if you had to leave.



Specifications

- Six free-standing sections
- Installation requires 800 square feet of space
- Five audio and video media components
- Mechanical, tactile, and low-tech interactives
- Various sized object cases
- Packed in 16 wheeled crates

Space must have access to

- electrical outlets and ensure that the exhibit is not displayed in direct sunlight to maintain the integrity of exhibition panels.

- Door height (and elevator door height as applicable) of 82in required.



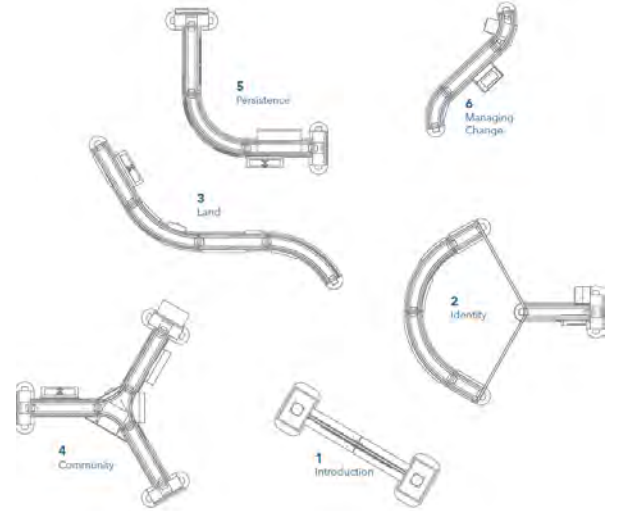
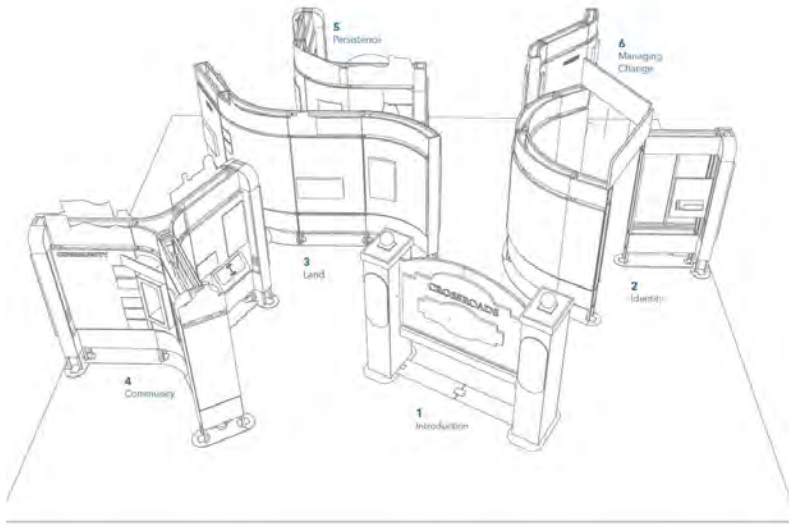



Section 1: Introduction

Americans come together at the crossroads. They invest in places and build their futures where their paths cross. Small towns became centers of commerce, trade, local politics, and culture. For some, the crossroads affirmed a new life in a new place. For others, the crossroads meant hard work and hard times.

Ideas intersect at these crossroads as well. Americans debate the meaning of independence and equality. They do not always agree, nor do they all benefit or profit from business or the decisions made. They face challenges with conviction. Some communities have declined, but most survive.

What is the future of rural America? How does “rural” effect American identify? What will the next one hundred years bring? Explore how small towns have changed over the past century and consider how we can reshape and re-envision our communities for the futures. Our rural communities are at a crossroads. Which direction will we choose?

- Change in Rural America: Sliding or flip-up panels explore different aspects of rural life that experienced great change over the past century. Panels include:
 - Education
 - Access to services
 - Commerce
 - Agriculture
 - Infrastructure
 - Demographic change

Section 2: Identity

Rural America is at the heart of our national identity. Those who came to America saw boundless plains ready for cultivation. Indigenous people saw their landscapes differently.

People moved into America from all directions, motivated by the opportunity to acquire seemingly limitless land with untapped resources. Settlers platted communities. Independent farmers grew crops and raised animals. Entrepreneurs built businesses at the crossroads. These rural communities fueled the nation’s growth.

Philosophers, politicians, and historians linked the so-called “frontier” experience to formation of a distinct American identity—one which supports economic opportunity, personal liberty, and equality. Popular culture reinforced this nostalgic view of rural America. Successful family farms and bustling Main Streets became a foundation of the “American dream.”

But, success was not guaranteed, and opportunities have not been available to everyone. Hard work, persistence, and sacrifice have become part of the rural identity as well, along with pride in a job well done.

- Rural America in the Popular Imagination: What are the popular perceptions of rural America? Family farms, country roads, and small-town Main Streets captivate the popular imagination. Artists, musicians, writers and others celebrate the richness and beauty of the American countryside and the people who live there. They romanticize hardy pioneers, independent family farmers, and crossroads settlements with their country schools and rural churches that became community centers. They praise Americans for working hard to build a better life for their families. They claim that the ideals of American democracy took root in country crossroads. Some offer a less positive perspective on rural America—American Indians losing their land, millions of Africans and their descendants enslaved, migrant laborers exploited by producers, workers laboring in extractive industries. Stereotypes of rural America abound, including the country bumpkin, the righteous prohibitionist, and the xenophobic member of the Ku Klux Klan.
- What is Rural? “Rural” means different things to different people. The United States Census Bureau has a very clear definition based on population statistics, defining rural as fewer than 2,500 people. Those who study rural America have called for a new definition because people use the term “country” more broadly. Most people say they live “in the country” when they live in a rural region, and others call county seats and suburbs “the country.” Is rural a state of mind? Is it an expanse of land? Is it a place to be? Is it merely a statistic? How do you define rural? **Can** you define rural?
 - The Rural America Bookshelf Interactive: Spines of classic books and DVD cases for famous films on rural America pull out to reveal more information about the book’s impact on popular interpretations of rural areas
 - Video program: “What is Rural: What Does Rural Mean to You?”: Rural Americans talk about their definitions of “rural” and what those definitions mean to them.
 - “Wheel of Rural” Interactive: Do you live in rural America? How do you know? A wheel-based interactive allows visitors to examine different definitions of rural and see where they fall into the mix.
- Living at the Rural Crossroads: Living and working in rural America has never been easy. It takes a commitment of time, sweat, and economic risk to live in the country. Finding well-paying jobs is challenging. Rural families often work more than one job to make ends meet. Many work shifts at manufacturing plants, mines, poultry processing plants, and cake mix factories. Others work seasonally at tourist attractions or on farms and orchards. Some face additional obstacles due to their race or ethnicity. Many rural people choose to move to urban and suburban areas for jobs, a more vibrant social and cultural life, and an escape from racism and other oppression. Those who leave may still identify strongly with and romanticize rural America, even though the reality of life is much more complicated.
 - Timeline: Images trace the major changes that had an impact on rural America from the late 19th century up to the present

Section 3: Land

Rural Americans build their homes, farms, businesses, communities, and sense of worth on land. Land is a finite resource. It is expensive and requires significant investment. Those who own land control resources under, on, and above it. Americans link the reality of ownership with the ideal of independence. They yearn for their own piece of land, which confirms their personal autonomy and symbolizes their political influence and contribution to the local economy. Many appreciate the open landscape and unobstructed views. Many develop a strong sense of place, an emotional, almost spiritual, connection between physical locations and their personal identity.

Sustaining the finite resource creates tension between private interest and public need. What does land mean to you? To your family? To your community? What does connection to land mean to us? How do communities mediate between private interest and public need?

- **Private Land—An “American” Idea (and Ideal):** Americans associate owning land with economic independence, personal autonomy, and political authority. Many people in crossroads communities do not own land. What relationships exist between landowners, the landless, and rural communities? Most Americans connect with rural places through public lands. They drive through village greens, hike in forest preserves, camp in state and national parks, and hunt and fish in recreation areas. These places help sustain emotional connections to the countryside, support rural and heritage tourism and local economic development, and protect the finite resource as a public asset. How do attitudes towards land differ among Americans? Is land ownership still part of the American dream?
- **Conflict Over Land:** Rural people do not agree about how to live in the same place. Different approaches to managing land creates political and social issues. European private land ownership shaped American realities from the beginning. This threatened indigenous populations who depended on the land for their livelihood. The sense of ownership affects rural communities in various ways. Some residents use their economic status to advocate for the public good while others devise ways to limit access or even exclude neighbors from equality and justice. Some claim public lands for their exclusive use. They justify it as their right and rationalize it as their prerogative because they do not consider public access to land as an entitlement.
 - **Objects:** Three cases feature documents related to land ownership like a deed of sale and an Indian removal notice and land survey and fencing tools
- **Sense of Place:** Many Americans express strong connections to the rural landscape. They intertwine their personal memories with hills and dales that they roamed as children and with landmarks that have special meaning. Many wax nostalgic about their hometown. They become emotional when they smell fresh-cut hay, when they fish on a river shore, hear the sounds of familiar birds or the roar of rivers in mountain canyons, smell the saltwater on the coast, and feel the blustery wind blowing across the desert. Beautiful places draw people to the countryside to explore the natural landscape. Some Americans fight to preserve natural lands across America to ensure that every American has the opportunity to experience them. Not everyone feels this attachment to the country. Some recall memories of isolation, hard work, and exclusion.
 - **“What Does Rural Sound Like?” Audio Interactive:** Visitors can sample sounds from rural environments like audio of tractors, crickets and peepers, running water, church bells, a local volunteer fire alarm, mining explosion horn, slamming of a screen door and a whistle for reporting to work or for shift changes.
 - **Flipbook:** Stories of Personal Connections to Land

Section 4: Community

Rural life revolves around crossroads communities--towns, villages, and rural hamlets. These communities are powerful, dynamic places where people connect--exchange ideas, work towards common goals, rely on neighbors, and build a future. Industries process agricultural goods. Stores and businesses manage trade. Schools, churches, and local organizations build cultural cohesion. Rural communities experienced economic growth in the early years of the 1900s, but they have faced dramatic change since then. Individuals, private associations, reform organizations, and state and national governments have intervened to help modernize

and improve rural America. Local residents have played a key role in creating communities that achieve their common goals and support their economic and lifestyle choices.

- **Main Street:** One of the most popular symbols of our crossroads communities is Main Street. Local residents created towns that reflected their needs and values. The growth in railroads and the arrival of the automobile by the early twentieth century led to a decline in smaller rural villages and hamlets and the growth in the railroad towns and county seats. Town and country people filled bustling streetscapes lined with stylish commercial buildings selling popular new goods. New theaters and opera houses showcased cultural entertainments. City parks provided stages for local band concerts. Public libraries offered a range of educational opportunities. Churches service the community's spiritual needs.
 - **Build Your Own Town Interactive:** Visitors will consider what town elements are needed to sustain a Main Street. Using blocks, visitors can build their own Main Street.
 - **Objects:** Case will include items from community organizations. Possible items are: memorabilia from fairs (ribbons or posters); items from theaters, dance halls, opera houses and music events (posters or playbills); decals; public notices; Chinese restaurant menus; funeral home fans; Mexican restaurant menus; church cookbooks (spiral-bound); church hymnal; rodeo flyer
- **Sustaining Community:** Rural communities have faced significant change over the past century. Town and farm people have worked together with local, state, and national governments to ensure their future. Local organizations and individuals often initiate change in rural communities. To be effective, they need support from community entrepreneurs and elected county officials, and often, the financial support of the state and federal governments. This can create tension between conservatives favoring small government and liberals favoring government action.
 - **Country Life Movement:** In 1908, President Teddy Roosevelt organized the Commission on Country Life with the charge to make rural America more attractive. Fearful that too many youth were leaving the country for the city, leaders like Liberty Hyde Bailey sought to “develop in the country community the great ideals of country life as well as of personal character.” Rural folk did not always agree with Country Life Movement goals. They wanted better roads, public schools, and mail delivery. What challenges did people want to solve in the early 1900s in your community? How did they approach reform?
 - **The New Deal:** Sometimes national and state governments played a significant role in managing change. During the Great Depression of the 1930s, President Franklin Delano Roosevelt proposed a series of programs to help Americans survive this difficult crisis. Many New Deal programs targeted struggling farmers and rural communities. Government public works programs built roads, schools, parks, libraries, and other community resources that survive today. Some agencies assisted with flood control, reforestation, and land conservation. Others sought to provide relief for farmers through loans or subsidies, often with mixed results. Public arts programs employed artists to bring their talents into the country. Many New Deal murals decorating the interiors of public buildings still attest to this legacy. What impact did the New Deal have on your area?
 - **An Electric Revolution:** The Rural Electrification Administration (REA) of 1935 brought electric power to the countryside. While many towns had electricity by this time, most people on the farm had to purchase expensive technology for this purpose. Small town leaders participated in this cooperative investment, which allowed farm families to improve their

- standards of living to match those in small towns nearby. These electrical cooperatives still provide power to many rural communities.
- Audio Component: Stories gathered from oral histories of farm families and extension agents about rural electrification and other changes and reforms, along with music and news programs from the 1930s. The component may be designed like a radio.
 - Objects: Case will include extension handbooks and leaflets; premium book from a fair; Rural Electrification Administration booklets
 - Flipbook on different New Deal projects
- Accelerating Change: World War II drew rural residents off the farms and away from the crossroads to wartime occupations. Few returned to the country permanently after the war. Many rural Americans settled in growing suburbs and cities. Yet, the number of people in rural America remained remarkably stable, and the migrants returned home for visits regularly. The rural population changed demographically, becoming more skewed towards an older population. Youth moved to new jobs in metropolitan areas, following opportunities in industry and business. Retirees returned to the country. Farmers replaced laborers with bigger machinery, synthetic herbicides and pesticides, and automated feeding and watering systems and milking systems for dairies. Many people claimed that rural America was in crisis. The counter-cultural changes sweeping the country also rippled through the nation's small towns.
 - Changes in Rural Business and Infrastructure: Work in rural America evolved during the 1950s. Agricultural jobs changed or disappeared as production shifted from family labor to mechanization. Locally-owned businesses on Main Street faced stiff competition from strip malls, box stores, and e-commerce. Rural industry relied on cheaper, non-union laborers to remain competitive or even moved overseas to reduce labor costs even more. Others adapted or closed. Investments in transportation systems affected rural America in contradictory ways. The new interstate system crisscrossed the nation. Trucks hauled raw materials to industries committed to making consumable goods in America. The new interstate highways bypassed small towns, moving traffic away from the Main Streets.
 - Changes in Rural Crossroads: America's crossroads communities anchored rural culture. Closing schools in small rural communities was one of the first signs of irreversible decline. Small communities lost their schools and community centers as school districts consolidated students into elementary, middle, and secondary schools. Aging populations struggled to sustain social and cultural organizations such as civic groups, Chambers of Commerce, Masonic lodges, and denominational churches. Still, rural Americans worked within their communities to address these challenges, drawing upon traditional sources of support. Church groups, community organizations, business leaders, and local industry helped sustain and often fund assistance to individuals and to community life.
 - Addressing Inequality and Poverty: In the 1950s and 1960s, rural Americans faced challenges that existed across America -- poverty, racism, cultural isolation, ethnic conflict, addiction, gender inequality, and culture clash. Much of the Civil Rights movement played out in rural America. Sit-ins occurred across the rural South. American Indians organized on reservations. Rural women took a stand for equal rights. National news media covered conflicts that erupted over rural issues such as school integration, voter mobilization, and equal employment. Equal rights movements raised many issues but did not solve the problems of who should fund rural relief, recovery, and reform. Legislation protected minorities on paper. Some people perceived the expansion of rights for

some as an infringement on their own freedoms. Resistance took many forms, often revolving around the right to bear arms and religious liberty. How has your community faced issues of poverty and injustice?

- Objects: Case will include items on rural activism, possibly including buttons from Freedom Riders and other Civil Rights movement memorabilia; farmers' movement memorabilia; and a program from Farm Aid

Section 5: Persistence

Rural Americans believe in their communities. They struggle to resolve issues rather than abandoning the places where they live. Change affects farm-dependent and open-country places differently than hardscrabble mountain tops or suburban and exurban counties at the edge of metropolitan areas. No solution works everywhere. People at the crossroads develop strategies that work for them. Rural people understand the unique challenges they face, and the importance of trying to solve them. Partnering with special interest groups as well as local, state, and national agencies and organizations can help their rural places persist.

- **Economic Survival:** Rural Americans remain committed to the ideals and unique cultural elements that tie them to their communities. Without an economic foundation, however, rural crossroads cannot sustain their identity. Rural communities seek a diverse economic base drawing on local entrepreneurs and outside investors. Community leaders strive for a mix of production, processing and consumption. A region with farmers, mills to process grain, companies that package foods, and stores to serve rural needs, have more opportunity to retain residents. Good schools and medical services, such as hospitals, help attract investors. National and global economic forces challenge local business owners, as well as competition from metropolitan areas. Big-box stores and national chains replace small, family-owned businesses in rural communities. Many crossroads survive with a Quik-Trip convenience store and a Dollar General. What changes has your community faced in preserving its local economy?
- **Rethinking Farming:** News reports often feature the retirement of a well-respected farmer and the loss of farmland to suburban growth. The economic crisis of the 1970s increased the sense of urgency in rural America to sustain family farms. Legislators at the state and national level link farming to issues of national security, social welfare, and rural economic development. Family farmers today take different approaches to sustain their businesses. Some follow corporate agribusiness practices to manage their high-cost integrated industry. Others embrace alternative approaches -- cultivating small acreages using draft animals and organic methods, producing artisanal products, and adopting community-supported agriculture strategies. Some satisfy their agricultural passion through "hobby farms." Many supplement their farm income with other off-farm jobs.
- **Main Street Revitalization:** Preserving Main Street starts with stabilizing the local economy, but also involves recognizing and developing the community's distinct identity and history. This process requires partnerships between residents, business owners, local governments, and civic and cultural organizations. Others contribute to these efforts, appreciating the value and importance of small town life. Not-for-profit organizations, state and national economic development agencies, and the US Department of Agriculture's rural development sustainability initiative all provide resources that can help locals revitalize small towns and Main Streets. The Main Street program, launched by the National Trust for Historic Preservation in 1980, encourages local partnerships to create vibrant downtowns. How have residents helped revitalize

Main Street in your town? What role does government or non-governmental organizations play?

- Touchable interactive element: Spin-up or revolving panels with craft items: wine bottle, alpaca wool, baskets
- The Attractions of a Country Life: Many Americans love the countryside. They relocate from suburbia, exchanging the slower pace and quiet surroundings for hours of commuting. Young people went “back to the land” to live their counterculture ideals. Some seek a less materialistic lifestyle. They invest in small acreage and establish gardens. The growing popularity of organic, locally-produced food links rural to urban through farmers’ markets, locavore movements and farm-to-table restaurants. Retirees invest in five-acre farmettes to live in comfort in a bucolic location. Those who come to rural areas to enjoy parks and recreation facilities, rural retreats, and outdoor activities such as hunting or hiking sometimes clash with local residents. All want to maintain their bit of rural America.
 - Ideals and Identity: Popular culture connects urban and suburban Americans to their “country cousins.” Television shows, movies, country songs, novels, and documentaries depict real rural issues such as poverty, discrimination, and suicide and murder. They also romanticize, satirize, and trivialize rural issues and lampoon urban values. “Country” sells. Western attire symbolizes a country lifestyle. Toys educate children about farms and country living. Harvest festivals, antique tractor shows, farm-cations, and living history farms all depict perspectives on “country” life. Rural Americans often take a break from the pressures of modern life by taking weekend drives in the country. Why is the idea of “country” still so enticing in our popular culture today? What do you think about how country is portrayed today?
 - “Why Do I Choose to Live Here” Video component: Interviews featuring people talking about why they choose to continue living in rural communities, and their opinions on values and the benefits of living there.
 - Objects: A case might include country-related lunchboxes, toys, DVDs, CDs, books and sheet music.

Section 6: Managing Change

People have strong but often differing opinions about important issues relating to rural America and its small-towns. In the twenty-first century, all Americans, including those in suburban and urban areas, will play an important role in shaping the future of rural America. As in the past, it is not just the people who live there but also “outsiders” who have a stake in its success. Solving challenges requires communication between people with different philosophical, class, and cultural identities. How can rural crossroads support a dialogue that sustains the place and retains the people? How can solutions balance long-standing American values such as equality, opportunity, civility, and human rights with personal liberty and laissez faire capitalism? How can rural communities serve the needs of all residents?

- Digital Interactive Device: A touchscreen computer will include video, audio, and photographic resources related to case studies of rural communities and to the exhibition sections. Most video and audio segments will feature interviews from across the country.
 - Case Study Categories:
 - Identity: What does rural mean to you today? How does your community reflect its rural heritage? What can small town residents do to be taken seriously by the majority of Americans? What are the stakes if small towns continue to lose leverage or remain misunderstood?

- Land: Most Americans living in rural places value and treasure the land. What are the issues we are currently facing in our community related to land use and conservation? How can we ensure that the natural landscape we have now is available for future generations to enjoy?
 - Sustainable Agriculture: How might we support locally-sourced agricultural operations?
 - Environmental Protection: How do we balance extractive industries in locations where rural communities depend on mining for economic livelihood and feel threatened by environmental protection?
- Community: What kind of community would you like to see in rural America? How is community still important to us?
 - History and the built environment: Much of our distinctive cultural history is expressed in the buildings that surround us every day-- on Main Street, on the farm, and in industrial areas. How can we preserve these buildings to reinforce our identity to ourselves and to others? How can we market that history through heritage tourism?
 - Education: How do we ensure that rural Americans get access to a good education in our community? How would we evaluate educational opportunities in our community?
 - Civic Dialogue: How do we meet the needs of a diverse community? How do we create opportunities for all residents to have their voices heard?
 - Cultural Life: What cultural attributes are important for your community? How can we achieve these? How do we create a vibrant community that celebrates the arts and humanities? What are the organizations we need to cultivate to create these opportunities for rural America?
- Persistence: How are communities sustaining themselves?
 - Rural Poverty, Personal and Community Well-being: How can rural communities maintain a safety net for poor residents without wealthy benefactors, social and cultural organizations, or government support?
 - Economy and jobs: What jobs defined your community in the past? What kinds of jobs are here now? What might you expect in the future? How do we create opportunities for all residents to experience economic opportunity? What will they be and are we training people to do those jobs? Telecommuting: more Americans are able to work at home.
 - Tourism
 - Politics: How do we work effectively between city and county governments? How do we interact with state politics?
 - Planning: With whom should communities partner to plan for the future? How do we include diverse voices in that planning process?